



INTERNATIONAL STANDARD



**Connectors for electrical and electronic equipment – Product requirements –
Part 3-122: Detail specification for 8-way, shielded, free and fixed connectors for
I/O and Gigabit Ethernet applications in harsh environments**

INTERNATIONAL
ELECTROTECHNICAL
COMMISSION

ICS 31.220.10

ISBN 978-2-8322-4276-6

Warning! Make sure that you obtained this publication from an authorized distributor.

CONTENTS

FOREWORD.....	4
1 Scope.....	7
2 Normative references	7
3 Terms and definitions	8
4 Mating information.....	9
4.1 General.....	9
4.2 Contacts – mating conditions	9
4.3 Fixed connector Type I	10
4.4 Free connector Type I.....	12
4.5 Fixed connector Type II	14
4.6 Free connector Type II.....	16
5 Characteristics	17
5.1 General.....	17
5.2 Pin and pair grouping assignment	17
5.3 Classification into climatic category	18
5.4 Electrical characteristics	19
5.4.1 Voltage proof.....	19
5.4.2 Voltage rating	19
5.4.3 Current-temperature derating.....	19
5.4.4 Initial insulation resistance	20
5.5 Mechanical characteristics	20
5.5.1 Mechanical operation.....	20
5.5.2 Insertion and withdrawal forces	20
5.6 Transmission performance	20
5.6.1 General	20
5.6.2 Insertion loss	21
5.6.3 Return loss	21
5.6.4 Near end cross talk.....	21
5.6.5 Far end cross talk	21
5.6.6 Transverse conversion loss	21
5.6.7 Transfer conversion transfer loss.....	21
5.6.8 Transfer impedance	21
6 Tests and test schedule.....	22
6.1 General.....	22
6.2 Arrangement for contact resistance test (Figure 8).....	22
6.3 Arrangement for vibration test (test phase DP3) (Figure 9).....	23
6.4 Test procedures and measuring methods.....	23
6.5 Preconditioning.....	24
6.6 Test schedules.....	24
6.6.1 General	24
6.6.2 Basic (minimum) test schedule	24
6.6.3 Full test schedule	24
7 Mounting of specimens	31

Figure 1 – Contact interface dimensions with a free (male) connector (right side) mated with a fixed (female) connector (left side)	9
---	---

Figure 2 – Fixed female connector Type I	10
Figure 3 – Free male connector Type I.....	12
Figure 4 – Fixed (female) connector Type II.....	14
Figure 5 – Free (male) connector Type II.....	16
Figure 6 – Fixed connector pin and pair grouping assignment for Type I (left, with coding edges on one short side) and Type II (right, with coding edges on one long side), front view of connector	18
Figure 7 – Connector de-rating curve	20
Figure 8 – Arrangement for contact resistance test	22
Figure 9 – Arrangement for vibration test.....	23
Table 1 – Dimensions for Figure 1	9
Table 2 – Dimensions for Figure 2	11
Table 3 – Dimensions for Figure 3	13
Table 4 – Dimensions for Figure 4	15
Table 5 – Dimensions for Figure 5	17
Table 6 – Pin assignment for 10/100 Mb Ethernet.....	18
Table 7 – Pin assignment for 1 Gb Ethernet.....	18
Table 8 – Climatic category.....	19
Table 9 – Test group P	25
Table 10 – Test group AP	25
Table 11 – Test group BP	27
Table 12 – Test group CP	28
Table 13 – Test group DP	29
Table 14 – Test group EP	30
Table 15 – Test group FP	31

INTERNATIONAL ELECTROTECHNICAL COMMISSION

**CONNECTORS FOR ELECTRICAL AND ELECTRONIC EQUIPMENT –
PRODUCT REQUIREMENTS –**

**Part 3-122: Detail specification for 8-way, shielded, free and fixed
connectors for I/O and Gigabit Ethernet applications
in harsh environments**

FOREWORD

- 1) The International Electrotechnical Commission (IEC) is a worldwide organization for standardization comprising all national electrotechnical committees (IEC National Committees). The object of IEC is to promote international co-operation on all questions concerning standardization in the electrical and electronic fields. To this end and in addition to other activities, IEC publishes International Standards, Technical Specifications, Technical Reports, Publicly Available Specifications (PAS) and Guides (hereafter referred to as “IEC Publication(s)”). Their preparation is entrusted to technical committees; any IEC National Committee interested in the subject dealt with may participate in this preparatory work. International, governmental and non-governmental organizations liaising with the IEC also participate in this preparation. IEC collaborates closely with the International Organization for Standardization (ISO) in accordance with conditions determined by agreement between the two organizations.
- 2) The formal decisions or agreements of IEC on technical matters express, as nearly as possible, an international consensus of opinion on the relevant subjects since each technical committee has representation from all interested IEC National Committees.
- 3) IEC Publications have the form of recommendations for international use and are accepted by IEC National Committees in that sense. While all reasonable efforts are made to ensure that the technical content of IEC Publications is accurate, IEC cannot be held responsible for the way in which they are used or for any misinterpretation by any end user.
- 4) In order to promote international uniformity, IEC National Committees undertake to apply IEC Publications transparently to the maximum extent possible in their national and regional publications. Any divergence between any IEC Publication and the corresponding national or regional publication shall be clearly indicated in the latter.
- 5) IEC itself does not provide any attestation of conformity. Independent certification bodies provide conformity assessment services and, in some areas, access to IEC marks of conformity. IEC is not responsible for any services carried out by independent certification bodies.
- 6) All users should ensure that they have the latest edition of this publication.
- 7) No liability shall attach to IEC or its directors, employees, servants or agents including individual experts and members of its technical committees and IEC National Committees for any personal injury, property damage or other damage of any nature whatsoever, whether direct or indirect, or for costs (including legal fees) and expenses arising out of the publication, use of, or reliance upon, this IEC Publication or any other IEC Publications.
- 8) Attention is drawn to the Normative references cited in this publication. Use of the referenced publications is indispensable for the correct application of this publication.
- 9) Attention is drawn to the possibility that some of the elements of this IEC Publication may be the subject of patent rights. IEC shall not be held responsible for identifying any or all such patent rights.

International Standard IEC 61076-3-122 has been prepared by subcommittee 48B: Electrical connectors, of IEC technical committee 48: Electrical connectors and mechanical structures for electrical and electronic equipment.

This first edition cancels and replaces IEC PAS 61076-3-122 published in 2015. This edition constitutes a technical revision.

The text of this International Standard is based on the following documents:

FDIS	Report on voting
48B/2554/FDIS	48B/2563/RVD

Full information on the voting for the approval of this International Standard can be found in the report on voting indicated in the above table.

This document has been drafted in accordance with the ISO/IEC Directives, Part 2.

A list of all parts in the IEC 61076 series, published under the general title *Connectors for electronic equipment – Product requirements*, can be found on the IEC website.

The committee has decided that the contents of this document will remain unchanged until the stability date indicated on the IEC website under "<http://webstore.iec.ch>" in the data related to the specific document. At this date, the document will be

- reconfirmed,
- withdrawn,
- replaced by a revised edition, or
- amended.

A bilingual version of this publication may be issued at a later date.

IMPORTANT – The 'colour inside' logo on the cover page of this publication indicates that it contains colours which are considered to be useful for the correct understanding of its contents. Users should therefore print this document using a colour printer.

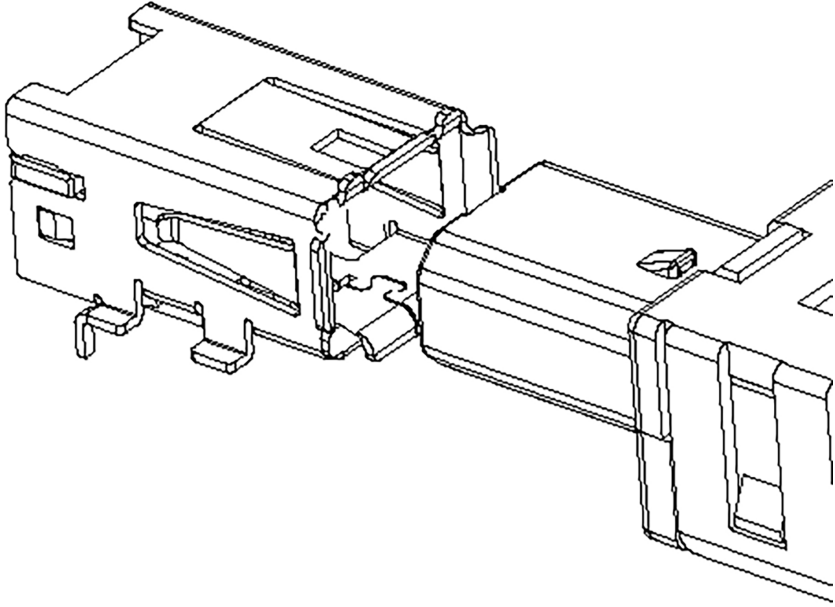
	IEC 61076-3-122:2017
Subcommittee 48B: Electrical connectors	
 <p style="text-align: right; margin-right: 20px;"><i>IEC</i></p>	<p>Detail specification for 8-way, shielded, free and fixed connectors for I/O and Gigabit Ethernet applications in harsh environments</p>
<p>NOTE The above view shows a Type I connector pair, with coding edges on a short side; for Type II connectors the coding edges are located on a long side.</p>	<p>Fixed connectors are mounted on printed circuit board by means of soldering or press-in, the free connector is attached to wires by means of soldering, crimping, IDC or other termination technology.</p>

CONNECTORS FOR ELECTRICAL AND ELECTRONIC EQUIPMENT – PRODUCT REQUIREMENTS –

Part 3-122: Detail specification for 8-way, shielded, free and fixed connectors for I/O and Gigabit Ethernet applications in harsh environments

1 Scope

This part of IEC 61076 covers 8-way, shielded, free and fixed rectangular connectors for I/O and Gigabit Ethernet applications, suitable for use in harsh environments, and is intended to specify the common dimensions, mechanical, electrical and environmental characteristics and tests for this family of connectors.

2 Normative references

The following documents are referred to in the text in such a way that some or all of their content constitutes requirements of this document. For dated references, only the edition cited applies. For undated references, the latest edition of the referenced document (including any amendments) applies.

IEC 60050-581, *International Electrotechnical Vocabulary (IEV) – Chapter 581: Electromechanical components for electronic equipment*

IEC 60068-1, *Environmental testing – Part 1: General and guidance*

IEC 60068-2-38, *Environmental testing – Part 2-38: Tests – Test Z/AD: Composite temperature/humidity cyclic test*

IEC 60512-1, *Connectors for electronic equipment – Tests and measurements – Part 1: General*

IEC 60512-1-1, *Connectors for electronic equipment – Tests and measurements – Part 1-1: General examination – Test 1a: Visual examination*

IEC 60512-1-2, *Connectors for electronic equipment – Tests and measurements – Part 1-2: General examination – Test 1b: Examination of dimension and mass*

IEC 60512-2-1, *Connectors for electronic equipment – Tests and measurements – Part 2-1: Electrical continuity and contact resistance tests – Test 2a: Contact resistance – Millivolt level method*

IEC 60512-3-1, *Connectors for electronic equipment – Tests and measurements – Part 3-1: Insulation tests – Test 3a: Insulation resistance*

IEC 60512-4-1, *Connectors for electronic equipment – Tests and measurements – Part 4-1: Voltage stress tests – Test 4a: Voltage proof*

IEC 60512-5-2, *Connectors for electronic equipment – Tests and measurements – Part 5-2: Current-carrying capacity tests – Test 5b: Current-temperature derating*

IEC 60512-6-3, *Connectors for electronic equipment – Tests and measurements – Part 6-3: Dynamic stress tests – Test 6c: Shock*

IEC 60512-6-4, *Connectors for electronic equipment – Tests and measurements – Part 6-4: Dynamic stress tests – Test 6d: Vibration (sinusoidal)*

IEC 60512-9-1, *Connectors for electronic equipment – Tests and measurements – Part 9-1: Endurance tests – Test 9a: Mechanical operation*

IEC 60512-11-3, *Connectors for electronic equipment – Tests and measurements – Part 11-3: Climatic tests – Test 11c: Damp heat, steady state*

IEC 60512-11-4, *Connectors for electronic equipment – Tests and measurements – Part 11-4: Climatic tests – Test 11d: Rapid change of temperature*

IEC 60512-11-7, *Connectors for electronic equipment – Tests and measurements – Part 11-7: Climatic tests – Test 11g: Flowing mixed gas corrosion test*

IEC 60512-11-9, *Connectors for electronic equipment – Tests and measurements – Part 11-9: Climatic tests – Test 11i: Dry heat*

IEC 60512-11-10, *Connectors for electronic equipment – Tests and measurements – Part 11-10: Climatic tests – Test 11j: Cold*

IEC 60512-13-2, *Connectors for electronic equipment – Tests and measurements – Part 13-2: Mechanical operation tests – Test 13b: Insertion and withdrawal forces*

IEC 60512-15-6, *Connectors for electronic equipment – Tests and measurements – Part 15-6: Connector tests (mechanical) – Test 15f: Effectiveness of connector coupling devices*

IEC 60512-26-100, *Connectors for electronic equipment – Tests and measurements – Part 26-100: Measurement setup, test and reference arrangements and measurements for connectors according to IEC 60603-7 – Tests 26a to 26g*

IEC 61076-1:2006, *Connectors for electronic equipment – Product requirements – Part 1: Generic specification*

IEC 61076-3, *Connectors for electronic equipment – Product requirements – Part 3: Rectangular connectors – Sectional specification*