

This is a preview - [click here to buy the full publication](#)



IEC 61758-1

Edition 1.0 2008-04

INTERNATIONAL STANDARD

**Fibre optic interconnecting devices and passive components – Interface
standard for closures –
Part 1: General and guidance**

INTERNATIONAL
ELECTROTECHNICAL
COMMISSION

PRICE CODE

R

ICS 33.180.20

ISBN 2-8318-9719-X

CONTENTS

FOREWORD.....	4
1 Scope.....	6
2 Normative references	7
3 Terms, definitions and abbreviations	8
3.1 Terms and definitions	8
3.2 Abbreviations	9
4 General description	9
4.1 Functional requirements	9
4.2 Environmental requirements	9
4.3 Functional closure parts	10
4.3.1 Primary function	10
4.3.2 Cover functional requirements	10
4.3.3 Base or end plate functional requirements	10
4.3.4 Opening and closing functional requirements.....	10
4.3.5 Closure seal functional requirements	10
4.3.6 General functional requirements	11
5 Closure overpressure safety.....	11
6 Grounding interface.....	11
7 General closure interfaces.....	11
8 Cable to closure interface.....	11
8.1 General.....	11
8.2 Functional requirements	11
8.2.1 General	11
8.2.2 Cable entry port.....	12
8.2.3 Repair, maintenance and testing	12
8.2.4 Moisture and gas ingress, sealing and blocking	12
8.2.5 Mechanical impacts	13
8.2.6 Cable and closure handling	13
8.2.7 Electrical continuity and lightning protection	13
8.2.8 Fire-related performance	13
8.2.9 Identification of cables and sub-parts	13
8.2.10 Biotic protection.....	13
8.2.11 Cable anchoring and supporting elements to closure	14
8.2.12 UV resistance.....	14
8.2.13 Resistance to aggressive media	14
9 Closure to FMS interface.....	14
9.1 General.....	14
9.2 Functional requirements	14
9.2.1 Mounting of the FMS to the closure	14
9.2.2 Identification.....	14
9.2.3 Access to FMS	15
9.2.4 Bending radius	15
9.2.5 Mechanical impacts	15
9.2.6 FMS grounding.....	15

9.2.7	Fire hazard (optional for indoor applications)	15
9.2.8	Laser safety.....	15
9.2.9	High optical power damage	15
10	Other parts of the closure interface	16
10.1	General.....	16
10.2	Passive components that may be included in a closure	16
10.2.1	xWDM	16
10.2.2	Moisture sensors	16
10.2.3	Security features	16
10.2.4	Connectors and adaptors.....	16
10.2.5	Pressure relief valves	16
10.2.6	Splitters/couplers.....	16
10.2.7	Optical switches	17
10.2.8	Desiccant	17
10.3	Active components that may be included in a closure	17
10.3.1	Moisture sensors	17
10.3.2	Security alarms.....	17
10.3.3	Optical switches	17
10.3.4	Converters.....	17
11	Closure interface to external siting	17
11.1	Functional requirements	17
11.2	Mounting of the closure to the external siting.....	17
11.3	Cable entry orientation	17
11.4	Identification.....	17
11.5	Access to closure and cable	17
11.6	Earthquake resistance.....	18
11.7	Closure grounding	18
11.8	Lightning protection.....	18
11.9	Fire hazard (optional for indoor applications).....	18
11.10	External siting of closure in aerial applications	18
	Bibliography.....	19
	Figure 1 – Closure and FMS functions	7

INTERNATIONAL ELECTROTECHNICAL COMMISSION

FIBRE OPTIC INTERCONNECTING DEVICES AND PASSIVE COMPONENTS – INTERFACE STANDARD FOR CLOSURES –

Part 1: General and guidance

FOREWORD

- 1) The International Electrotechnical Commission (IEC) is a worldwide organisation for standardization comprising all national electrotechnical committees (IEC National Committees). The object of IEC is to promote international co-operation on all questions concerning standardization in the electrical and electronic fields. To this end and in addition to other activities, IEC publishes International Standards, Technical Specifications, Technical Reports, Publicly Available Specifications (PAS) and Guides (hereafter referred to as “IEC Publication(s)”). Their preparation is entrusted to technical committees; any IEC National Committee interested in the subject dealt with may participate in this preparatory work. International, governmental and non-governmental organisations liaising with the IEC also participate in this preparation. IEC collaborates closely with the International Organisation for Standardization (ISO) in accordance with conditions determined by agreement between the two organisations.
- 2) The formal decisions or agreements of IEC on technical matters express, as nearly as possible, an international consensus of opinion on the relevant subjects since each technical committee has representation from all interested IEC National Committees.
- 3) IEC Publications have the form of recommendations for international use and are accepted by IEC National Committees in that sense. While all reasonable efforts are made to ensure that the technical content of IEC Publications is accurate, IEC cannot be held responsible for the way in which they are used or for any misinterpretation by any end user.
- 4) In order to promote international uniformity, IEC National Committees undertake to apply IEC Publications transparently to the maximum extent possible in their national and regional publications. Any divergence between any IEC Publication and the corresponding national or regional publication shall be clearly indicated in the latter.
- 5) IEC provides no marking procedure to indicate its approval and cannot be rendered responsible for any equipment declared to be in conformity with an IEC Publication.
- 6) All users should ensure that they have the latest edition of this publication.
- 7) No liability shall attach to IEC or its directors, employees, servants or agents including individual experts and members of its technical committees and IEC National Committees for any personal injury, property damage or other damage of any nature whatsoever, whether direct or indirect, or for costs (including legal fees) and expenses arising out of the publication, use of, or reliance upon, this IEC Publication or any other IEC Publications.
- 8) Attention is drawn to the Normative references cited in this publication. Use of the referenced publications is indispensable for the correct application of this publication.
- 9) Attention is drawn to the possibility that some of the elements of this IEC Publication may be the subject of patent rights. IEC shall not be held responsible for identifying any or all such patent rights.

International Standard IEC 61758-1 has been prepared by subcommittee 86B: Fibre optic interconnecting devices and passive components, of IEC technical committee 86: Fibre optics.

The text of this standard is based on the following documents:

FDIS	Report on voting
86B/2683/FDIS	86B/2712/RVD

Full information on the voting for the approval of this standard can be found in the report on voting indicated in the above table.

This publication has been drafted in accordance with the ISO/IEC Directives, Part 2.

A list of all parts of the IEC 61758 series, published under the general title *Fibre optic interconnecting devices and passive components – Interface standard for closures*, can be found on the IEC website.

The committee has decided that the contents of this publication will remain unchanged until the maintenance result date indicated on the IEC web site under "<http://webstore.iec.ch>" in the data related to the specific publication. At this date, the publication will be

- reconfirmed,
- withdrawn,
- replaced by a revised edition, or
- amended.

A bilingual version of this publication may be issued at a later date.

FIBRE OPTIC INTERCONNECTING DEVICES AND PASSIVE COMPONENTS – INTERFACE STANDARD FOR CLOSURES –

Part 1: General and guidance

1 Scope

This part of IEC 61758 provides general information and guidance on the subject of closures. It includes references, general closure and interface descriptions and definitions.

This standard defines the following general interfaces for closures:

- interface to cables;
- interface to FMS;
- interface to parts other than FMS or cables;
- interface to external sitings (pits, manholes etc.)

This specification covers all types of closures. The performance requirements are given in IEC 61753-111 series (in preparation).

This closure standard allows both single mode and multi-mode fibre to be used, and covers all IEC standard optical fibre cables as listed in Clause 2, with their various fibre capacities, types and designs.

Figure 1 shows and defines the interface between the closure and the fibre management system.

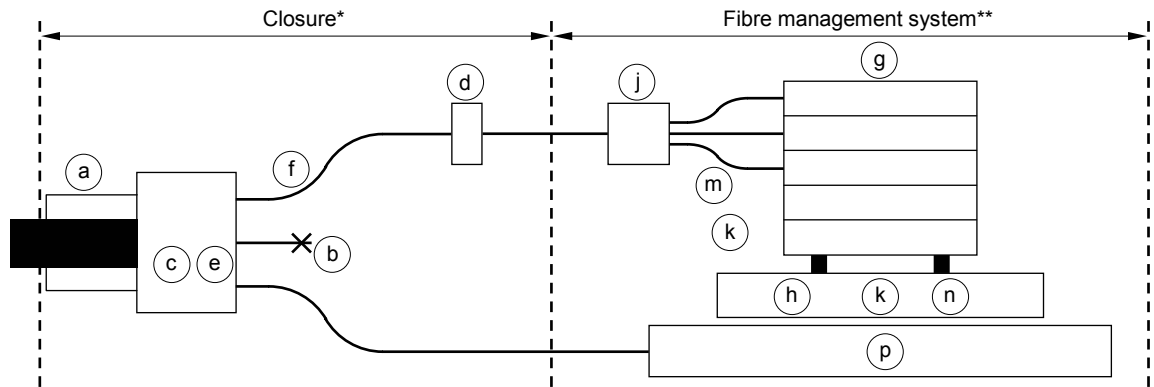

IEC 532/08

Key

Closure functions*

- (a) Cable sealing
- (b) Cable anchorage
- (c) Cable blockage
- (d) Cable gas blocking
- (e) Distribution element
- (f) Identification

FMS functions**

- (g) Organiser/splice tray(s)
- (h) Fibre storage
- (j) Distribution element
- (k) Passive components
- (m) Guiding elements
- (n) Connectors
- (p) Cable element storage

* Example of Closure

** Example of FMS

Figure 1 – Closure and FMS functions

2 Normative references

The following referenced documents are indispensable for the application of this document. For dated references, only the edition cited applies. For undated references, the latest edition of the referenced document (including any amendments) applies.

IEC 60068-3-3, *Environmental testing – Part 3: Guidance – Seismic test methods for equipment*

IEC 60721-2-6, *Classification of environmental conditions – Part 2: Environmental conditions appearing in nature – Earthquake vibration and shock*

IEC 60793-2 (all parts), *Optical fibres – Part 2: Product specifications*

IEC 60794-2 (all parts), *Optical fibre cables – Part 2: Indoor cables*

IEC 60794-3 (all parts), *Optical fibre cables – Part 3: Outdoor cables*

IEC 60825-2, *Safety of laser products – Part 2: Safety of optical fibre communication systems (OFCS)*

IEC 61300 (all parts), *Fibre optic interconnecting devices and passive components – Basic test and measurement procedures*

IEC 61753 (all parts), *Fibre optic interconnecting devices and passive components performance standard*

IEC 61753-1, *Fibre optic interconnecting devices and passive components performance standard – Part 1 – General and guidance for performance standards*

IEC 61756-1, *Fibre optic interconnecting devices and passive components – Interface standard for fibre management systems – Part 1: General and guidance*

IEC/TR 62222, *Fire performance of communication cables installed in buildings*