**Information technology —
Telecommunications and information
exchange between systems — Near Field
Communication Wired Interface (NFC-WI)**

*Technologies de l'information — Téléinformatique — Interface câblée
de communication de champs proche (NFC-WI)*

PDF disclaimer

This PDF file may contain embedded typefaces. In accordance with Adobe's licensing policy, this file may be printed or viewed but shall not be edited unless the typefaces which are embedded are licensed to and installed on the computer performing the editing. In downloading this file, parties accept therein the responsibility of not infringing Adobe's licensing policy. The ISO Central Secretariat accepts no liability in this area.

Adobe is a trademark of Adobe Systems Incorporated.

Details of the software products used to create this PDF file can be found in the General Info relative to the file; the PDF-creation parameters were optimized for printing. Every care has been taken to ensure that the file is suitable for use by ISO member bodies. In the unlikely event that a problem relating to it is found, please inform the Central Secretariat at the address given below.

**COPYRIGHT PROTECTED DOCUMENT**

© ISO/IEC 2007

All rights reserved. Unless otherwise specified, no part of this publication may be reproduced or utilized in any form or by any means, electronic or mechanical, including photocopying and microfilm, without permission in writing from either ISO at the address below or ISO's member body in the country of the requester.

ISO copyright office
Case postale 56 • CH-1211 Geneva 20
Tel. + 41 22 749 01 11
Fax + 41 22 749 09 47
E-mail copyright@iso.org
Web www.iso.org

Published in Switzerland

Contents

Page

Foreword.....	iv
Introduction	v
1 Scope	1
2 Terms and definitions.....	1
3 Conventions and notations	1
3.1 Representation of bit values.....	1
3.2 Representation of logical states of LOW and HIGH	1
3.3 Capitalisation of names.....	2
3.4 State notation	2
4 Symbols and abbreviated terms	2
5 General.....	2
6 Signals	3
6.1 Signal wires	3
6.2 Electrical characteristics	3
6.3 Clock frequency (f_{CLK}).....	4
7 NFC-WI states.....	4
7.1 Off state	5
7.2 Activating state	5
7.3 On state.....	7
7.4 De-Activating state	8
7.5 Command state	9
8 Information-transfer.....	10
8.1 Manchester bit coding.....	10
8.2 Modified Miller bit coding	10
8.3 Bit coding for $f_{CLK}/128$ (~106 kb/s)	11
8.4 Bit coding for $f_{CLK}/64$ (~212 kb/s)	11
8.5 Bit coding for $f_{CLK}/32$ (~424 kb/s)	12
Annex A (informative) Application of NFC-WI with NFCIP-1.....	13
Annex B (informative) Command state configuration.....	17

Foreword

ISO (the International Organization for Standardization) and IEC (the International Electrotechnical Commission) form the specialized system for worldwide standardization. National bodies that are members of ISO or IEC participate in the development of International Standards through technical committees established by the respective organization to deal with particular fields of technical activity. ISO and IEC technical committees collaborate in fields of mutual interest. Other international organizations, governmental and non-governmental, in liaison with ISO and IEC, also take part in the work. In the field of information technology, ISO and IEC have established a joint technical committee, ISO/IEC JTC 1.

International Standards are drafted in accordance with the rules given in the ISO/IEC Directives, Part 2.

The main task of the joint technical committee is to prepare International Standards. Draft International Standards adopted by the joint technical committee are circulated to national bodies for voting. Publication as an International Standard requires approval by at least 75 % of the national bodies casting a vote.

Attention is drawn to the possibility that some of the elements of this document may be the subject of patent rights. ISO shall not be held responsible for identifying any or all such patent rights.

ISO/IEC 28361 was prepared by Ecma International (as ECMA-373) and was adopted, under a special “fast-track procedure”, by Joint Technical Committee ISO/IEC JTC 1, *Information technology*, in parallel with its approval by national bodies of ISO and IEC.

Introduction

Following the standardisation of Near Field Communication (NFC) systems and their test methods in Ecma International, this International Standard specifies a two-wire interface between two components called “Transceiver” and “Front-end”. Systems that implement the NFC-WI interface can thus be augmented with, for example, a wireless Front-end for NFCIP-1 as illustrated in Figure 1. Although this International Standard only specifies requirements for the Signal-In and Signal-Out wires and the digital signals they carry, informative Annex A lists some NFCIP-1 specific considerations.

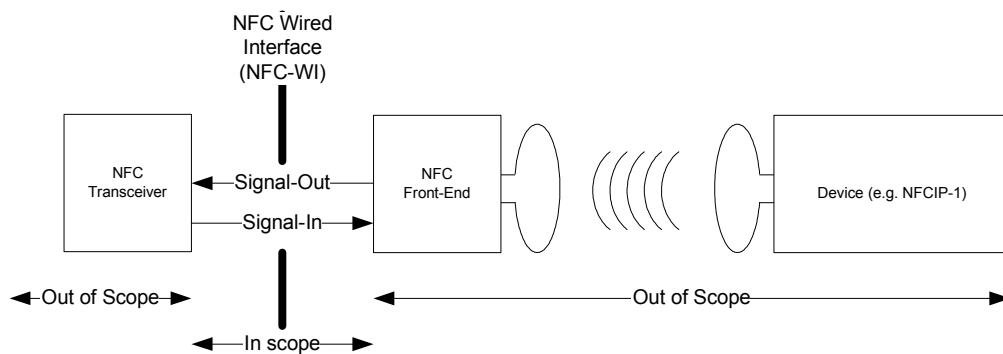

Figure 1 — Context diagram for the NFC wired interface

Information technology — Telecommunications and information exchange between systems — Near Field Communication Wired Interface (NFC-WI)

1 Scope

This International Standard specifies the digital wire interface between a Transceiver and a Front-end. The specification includes the signal wires, binary signals, the state diagrams and the bit encodings for three data rates.